



MACKENZIE COUNTY
ECONOMIC DEVELOPMENT STRATEGY
AND STREETScape DESIGN

La Crete

Introduction

OBJECTIVE

La Crete's streetscape creates a vibrant and active downtown that is pedestrian-oriented, retail-focused and is unique to La Crete.

La Crete Context



Masterplan

La Crete Masterplan

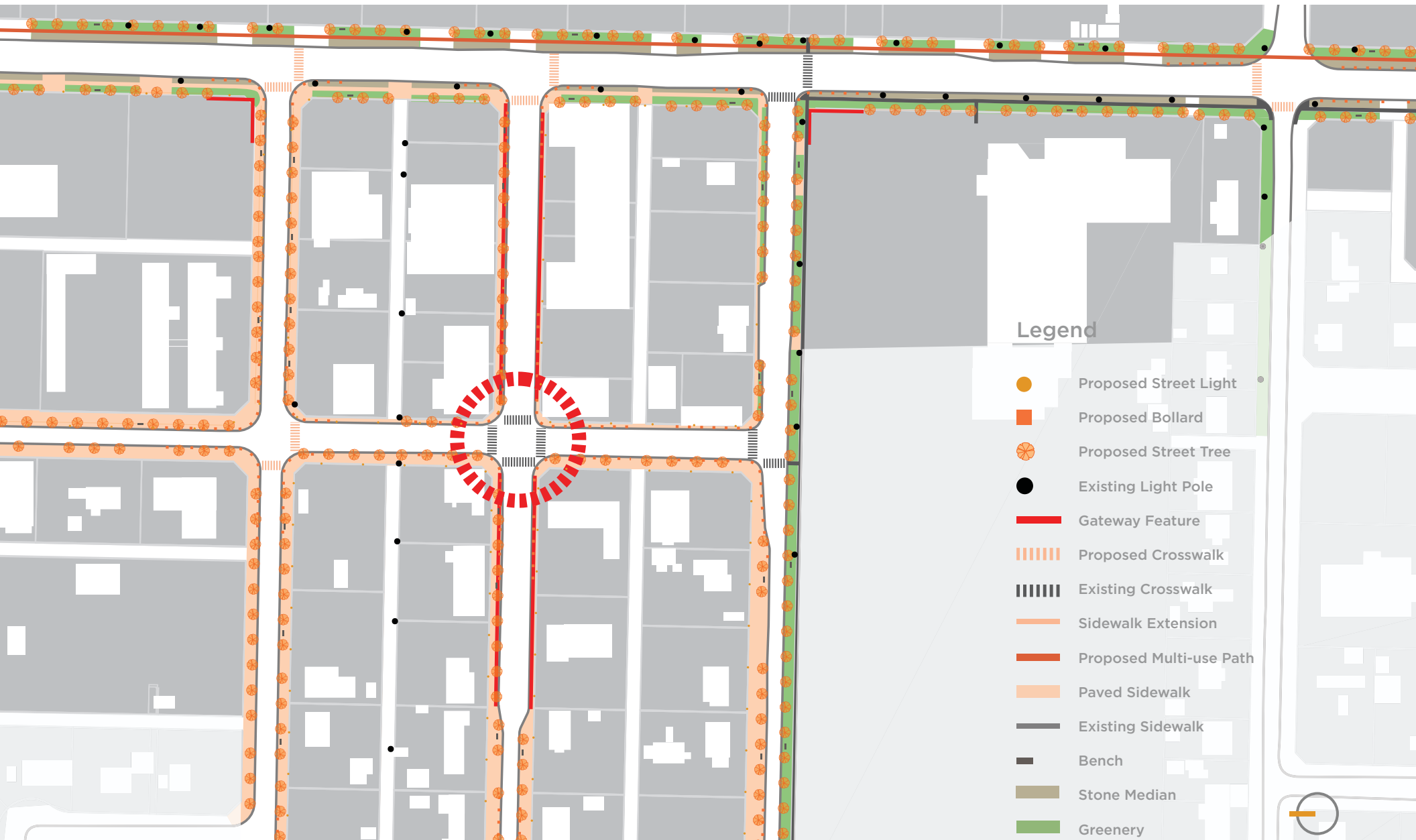

Streetscape Design

La Crete Downtown Plan

Cross Section at 100 Ave and 101 St

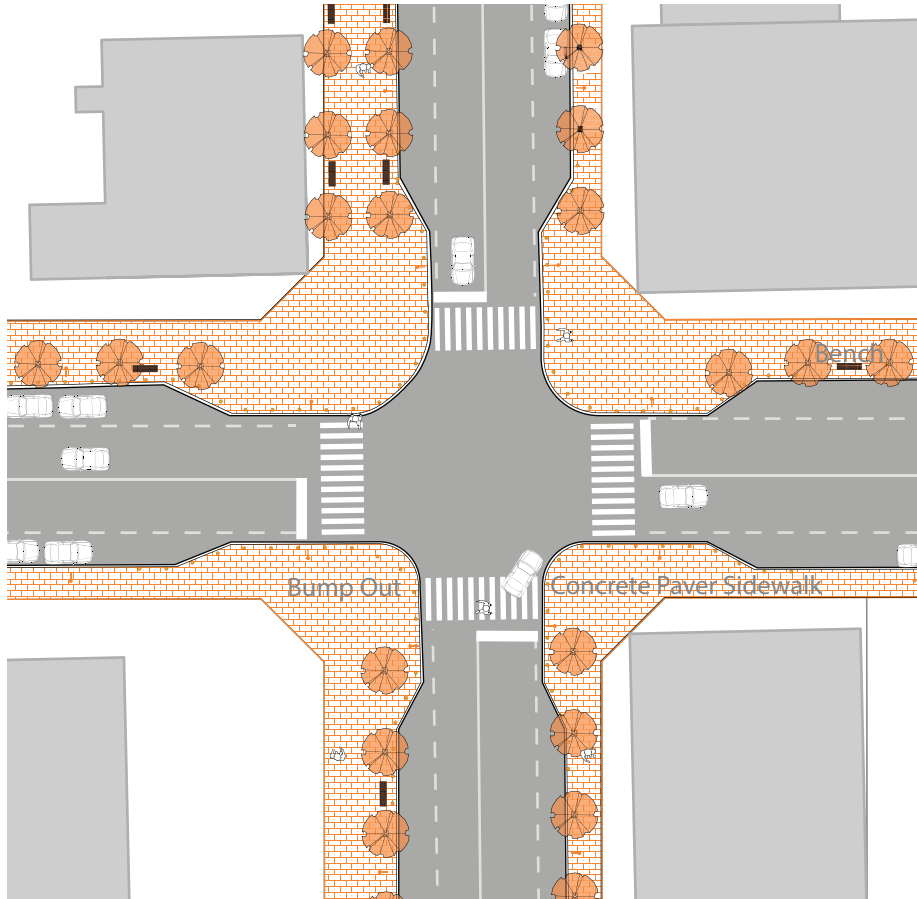

Safety Crossing Precedent



Sidewalk Paving Standard

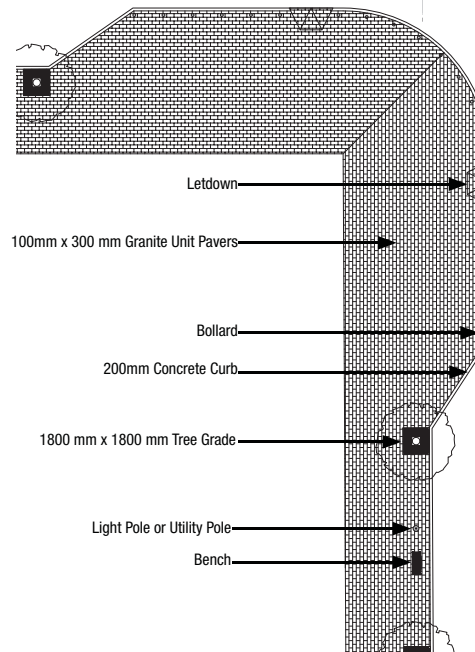

La Crete 100 St Plan

Section of 100 St

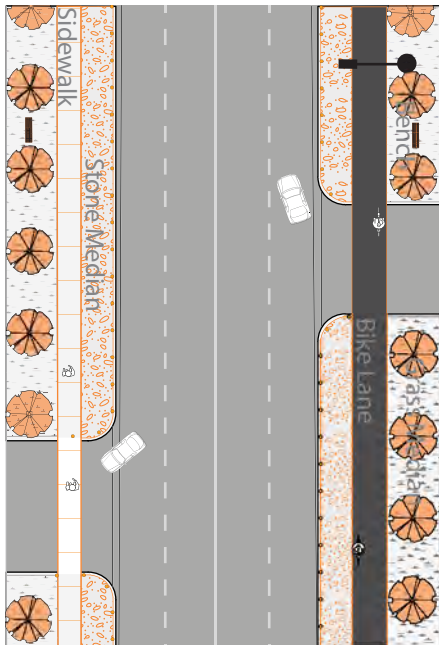

Stone Median Against 100 St



Key Map

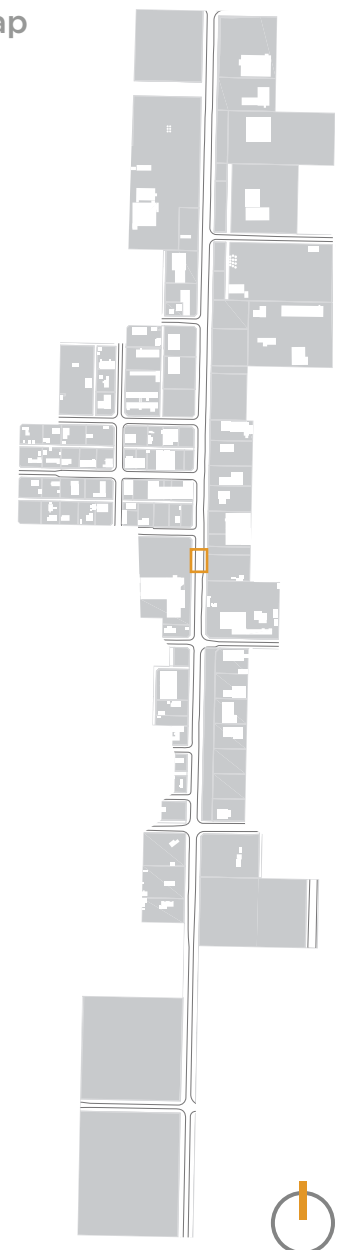

Painted Tree Guard

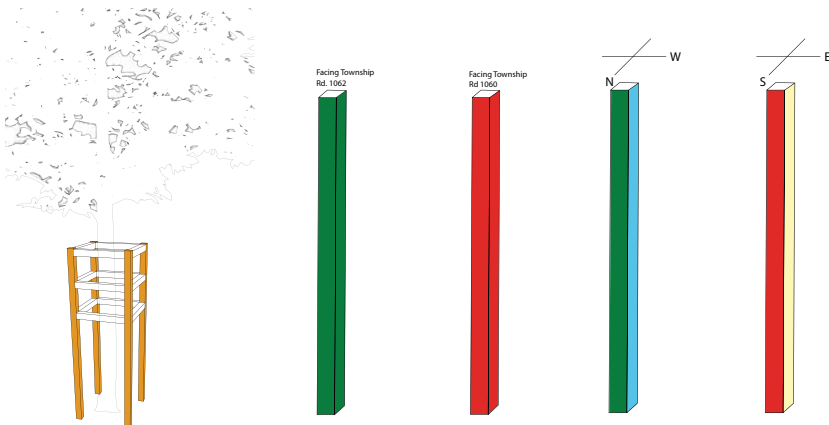

La Crete Street Section

Section A



Section B



- Roadway Zone
- Roadway Zone - Parking
- Edge Zone
- Furnishing and Planting Zone
- Sidewalk Zone
- Frontage and Marketing Zone



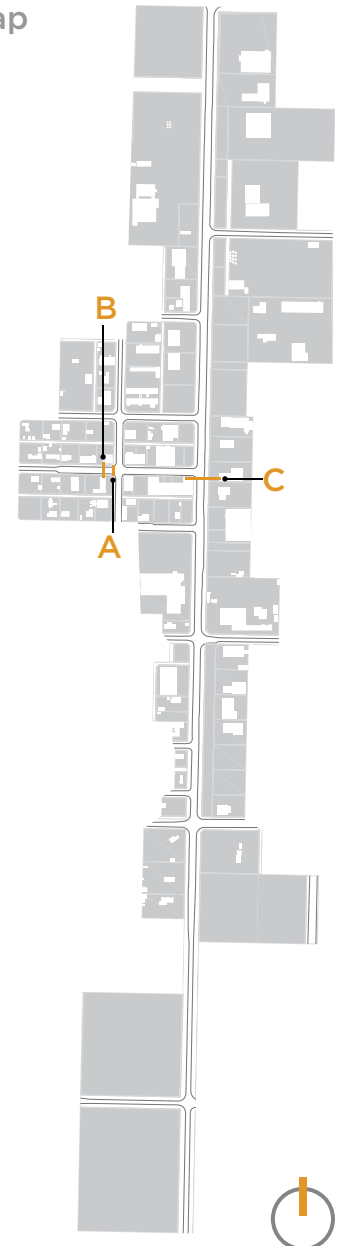

Key Map



La Crete Street Section

Section C



-  Roadway Zone
-  Roadway Zone - Parking
-  Edge Zone
-  Furnishing and Planting Zone
-  Sidewalk Zone
-  Multi-use Sidewalk
-  Frontage and Marketing Zone

La Crete Downtown Furniture Design

Bollard



Garbage Bin



Bench



Pedestrian light



Banner on Street Light

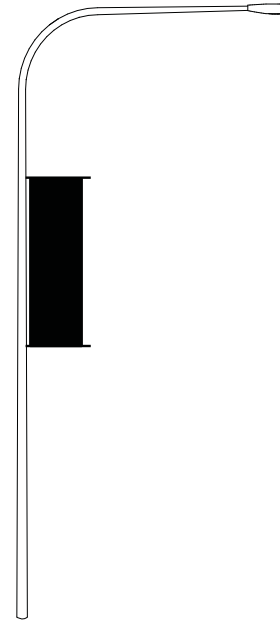

La Crete Furniture Design

Bollard



Garbage Bin



Bench



Gateway Light Pole

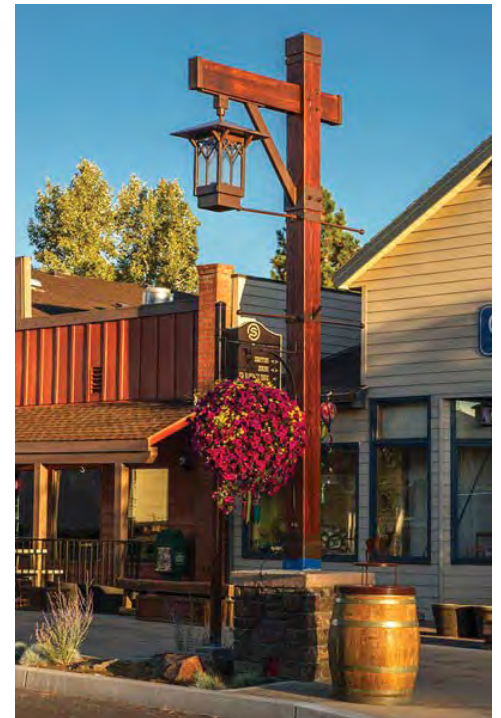
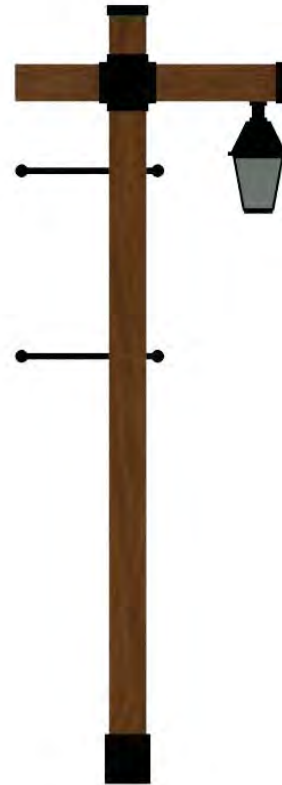

La Crete Promenade Identity



La Crete Promenade Identity



La Crete Downtown Gateway Feature



Gateway at 100 St and 101 Ave

Fort Vermilion

Introduction

OBJECTIVE

Fort Vermilion's streetscape encourages walking, celebrates local history and enhances the experience of the Peace River for both visitors and residents of the hamlet.

Fort Vermilion Context



Fort Vermilion Masterplan

Fort Vermilion Furniture Design

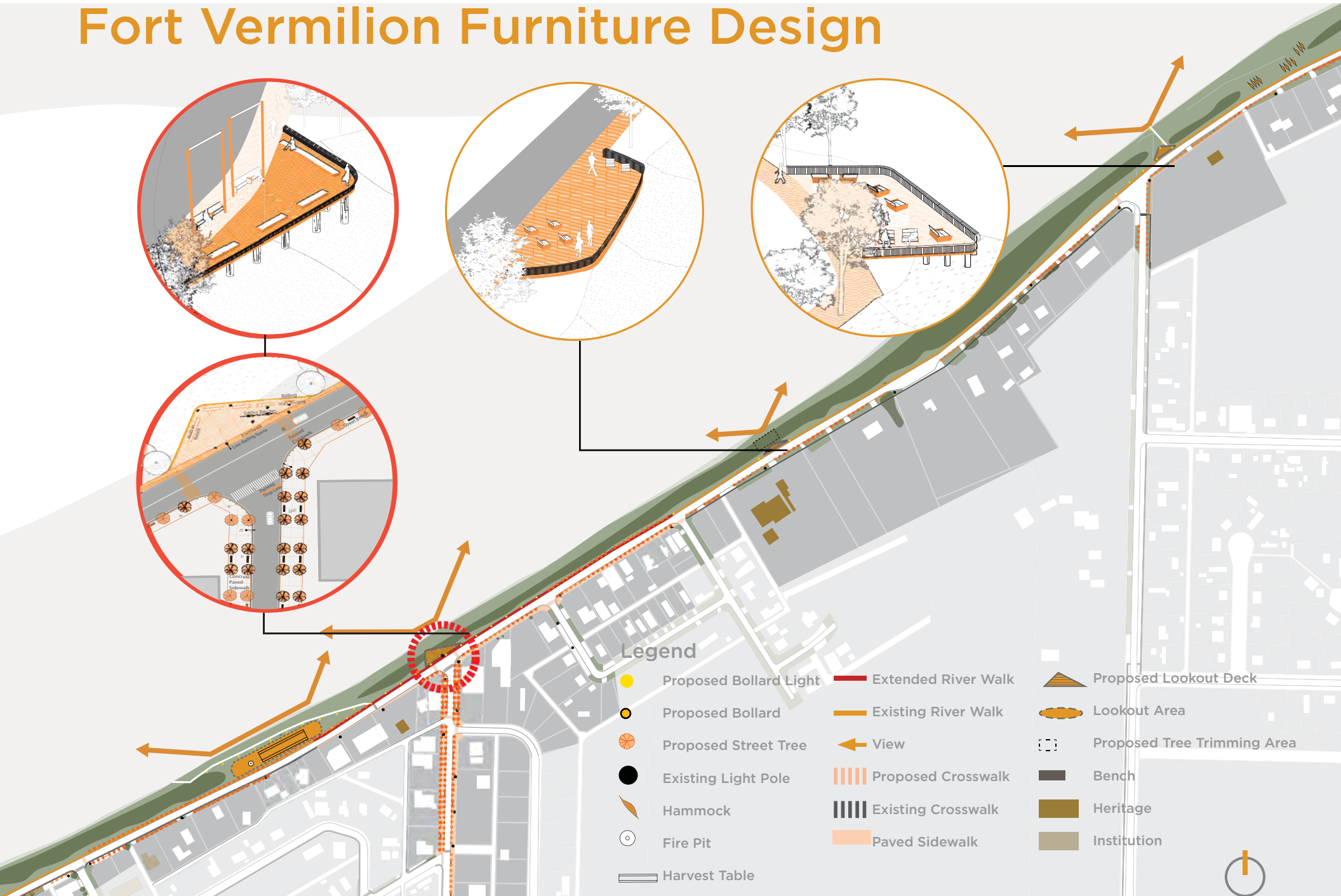

Fort Vermilion Streetscape Design

Fort Vermilion Street Sections

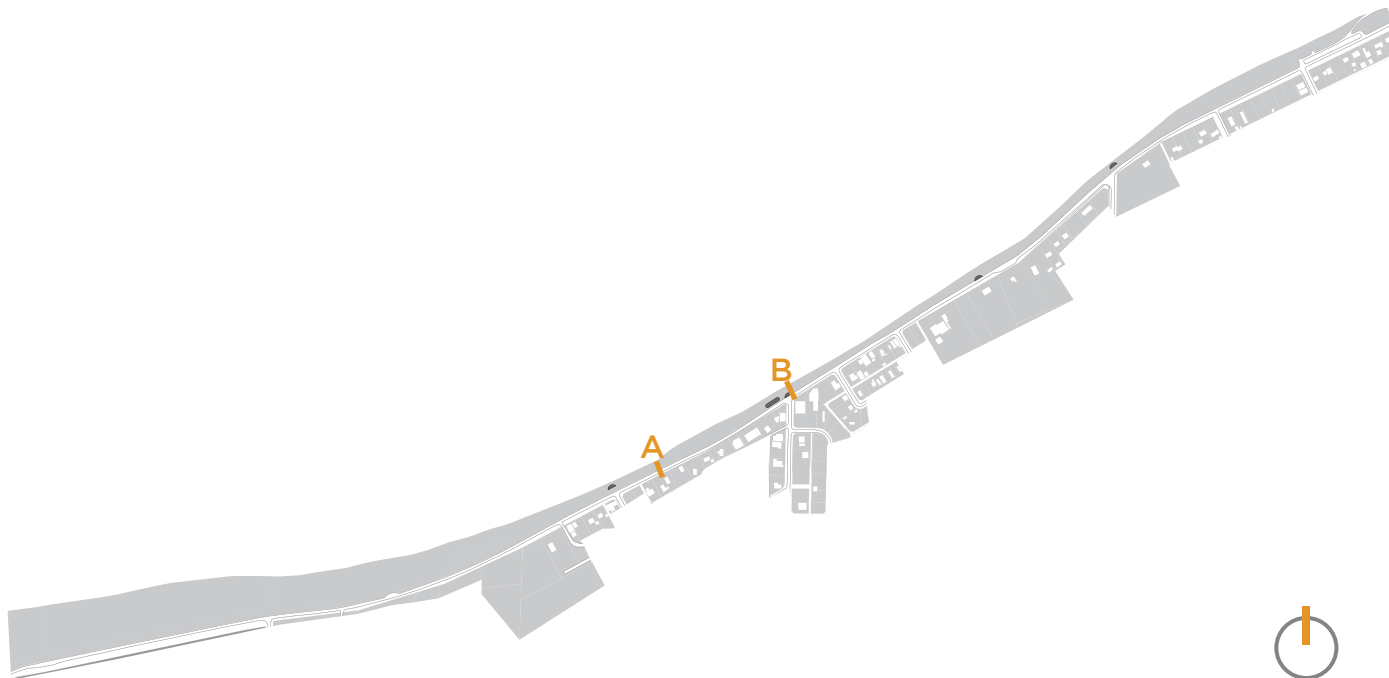
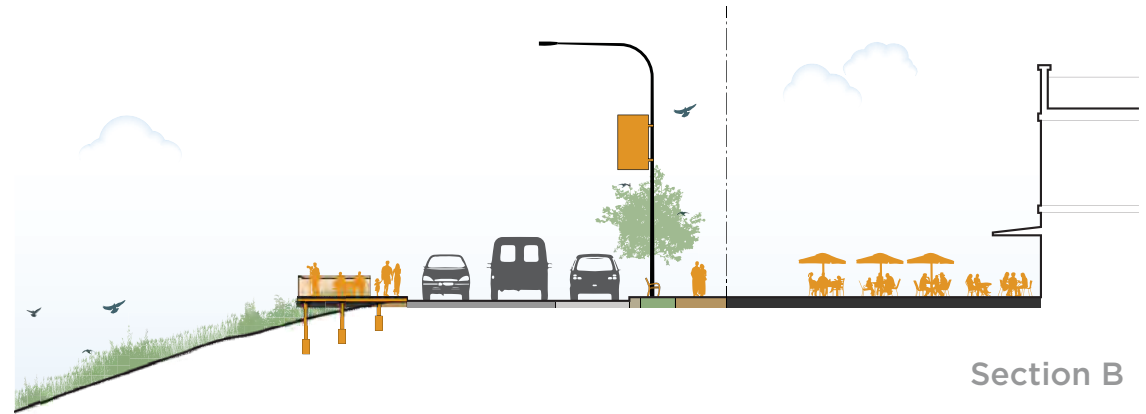
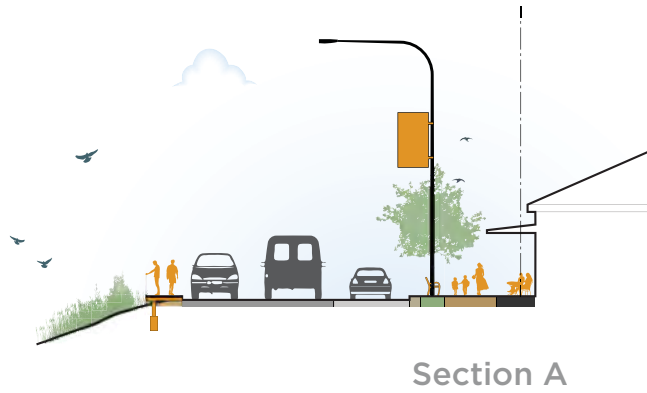

- Roadway Zone
- Roadway Zone - Parking
- Edge Zone
- Furnishing and Planting Zone
- Sidewalk Zone
- Frontage and Marketing Zone

Fort Vermilion Street Sections

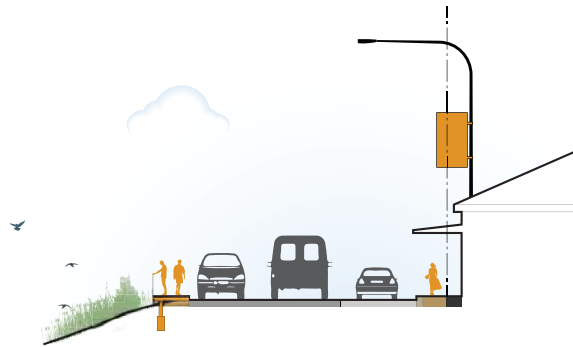

Section C



Section D

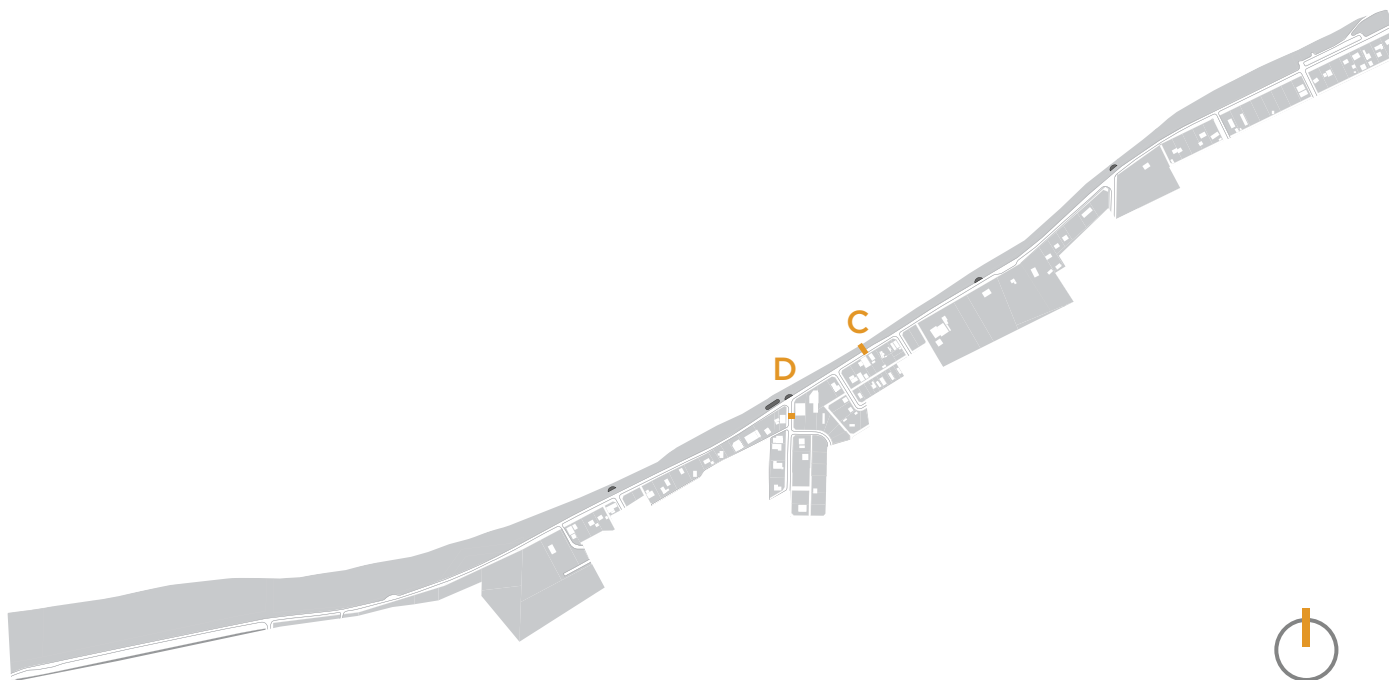

- Roadway Zone
- Roadway Zone - Parking
- Edge Zone
- Furnishing and Planting Zone
- Sidewalk Zone
- Frontage and Marketing Zone



Fort Vermilion Furniture Design

Front View

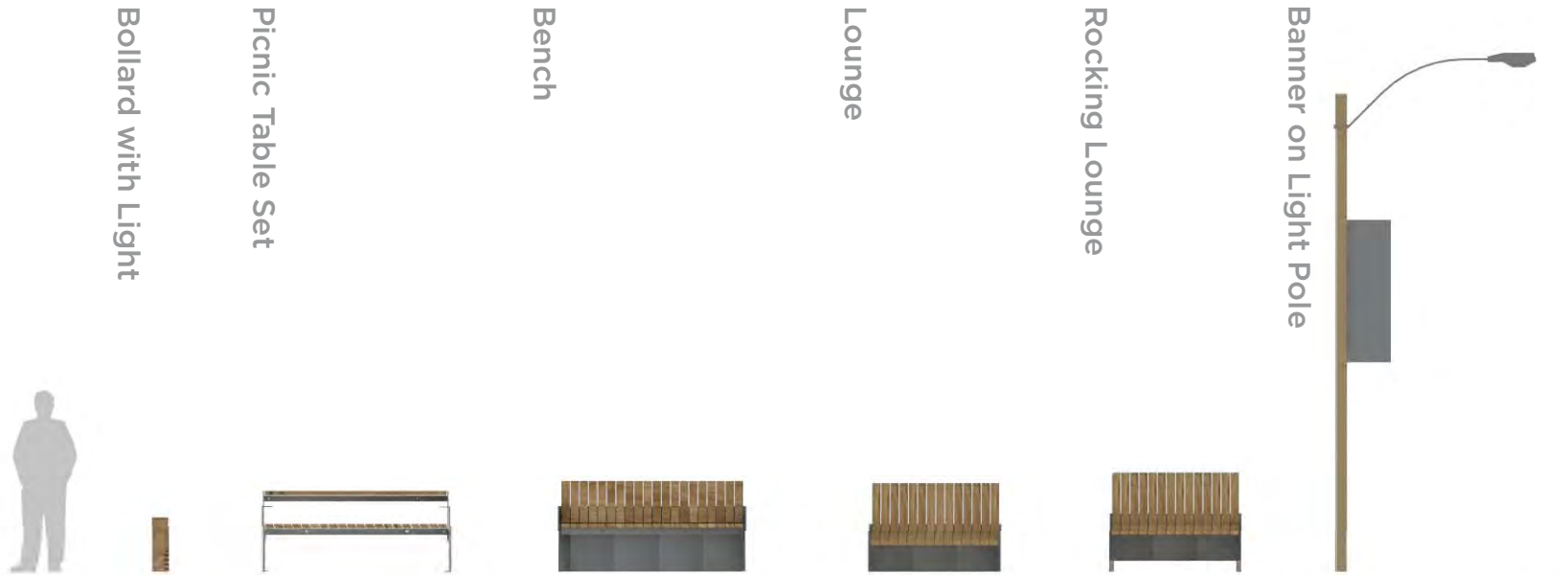

Perspective View

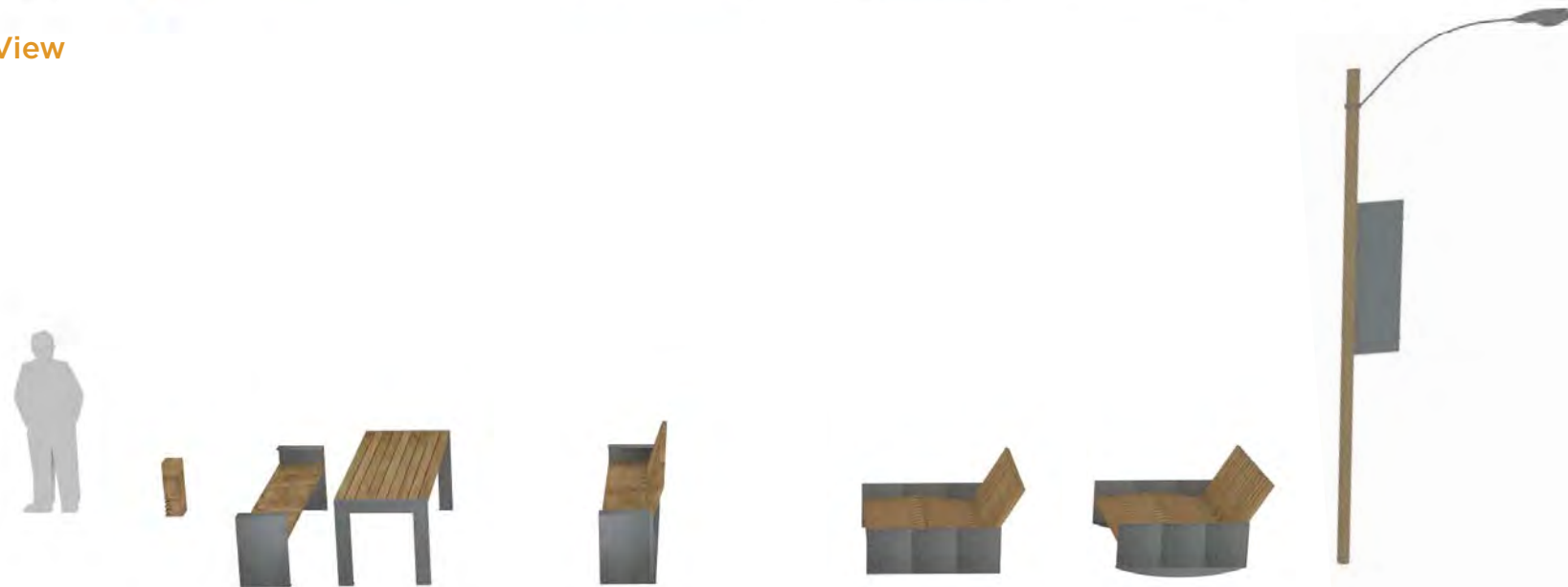

Fort Vermilion Wayfinding

Front View

Heritage Signage



Gateway Signage



Way-finding Signage



Gateway Wind Break

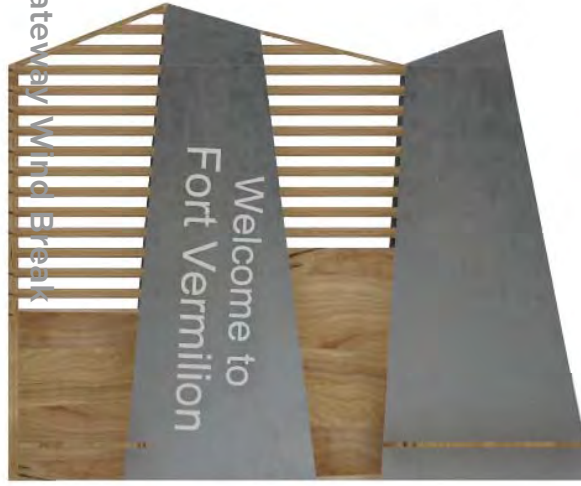

Gateway Swing Bench

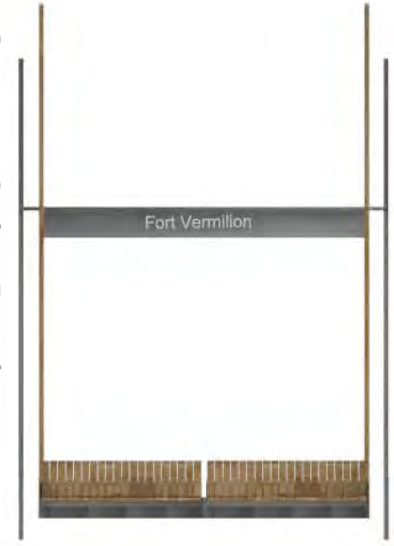

Perspective View



Fort Vermilion Furniture Design Application

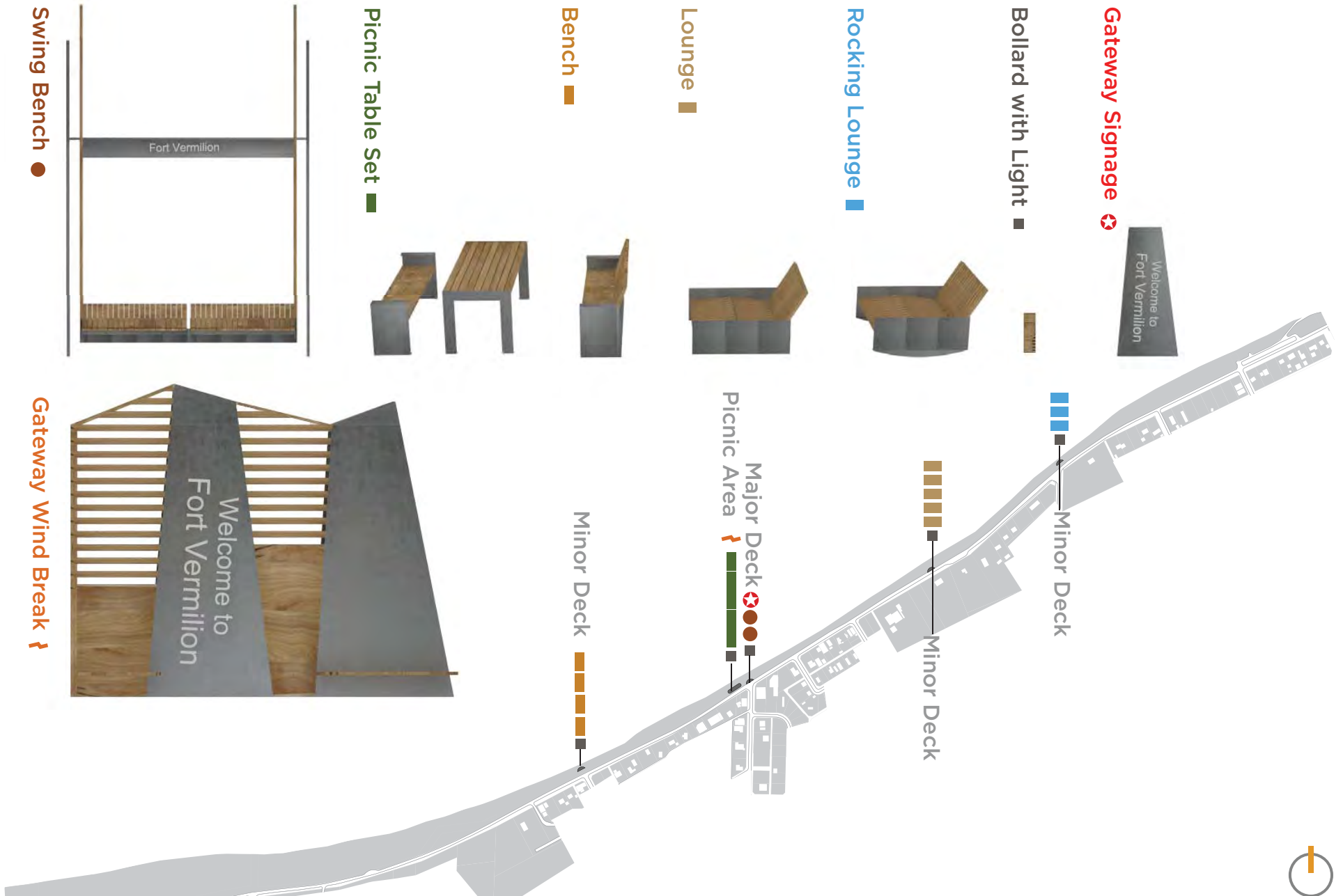

Fort Vermilion Furniture Design Application

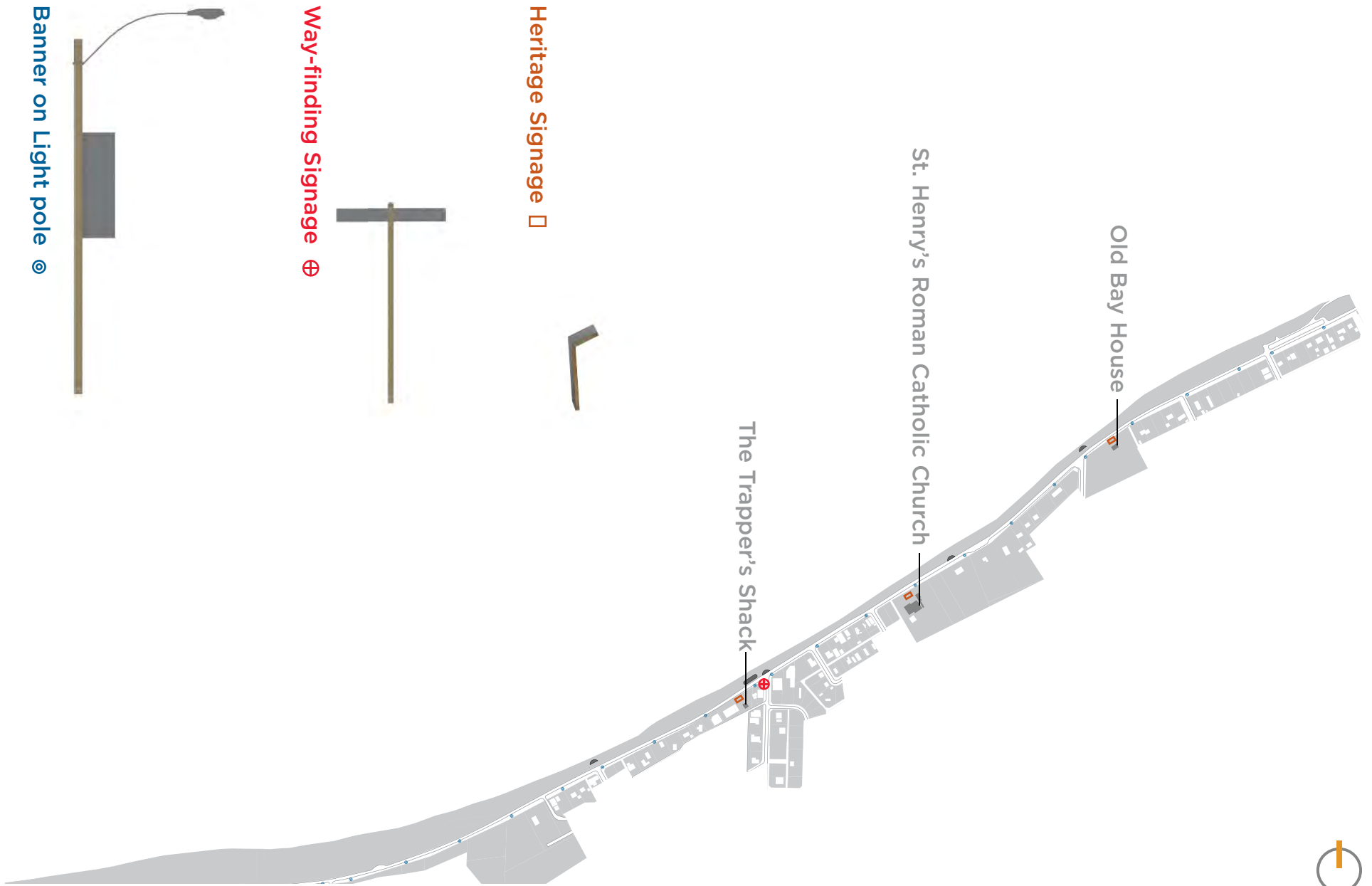

Fort Vermilion Gateway Feature



Fort Vermilion Gateway Feature



Fort Vermilion Gateway Feature



Site Guideline

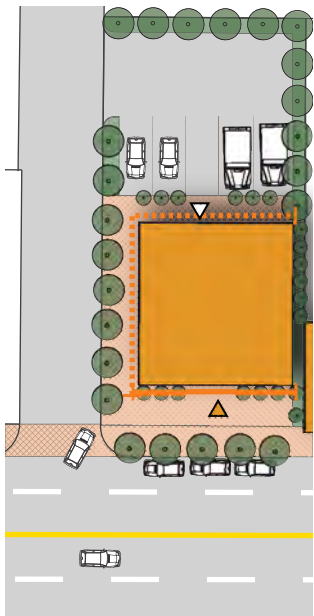

Small Lot
Option 1

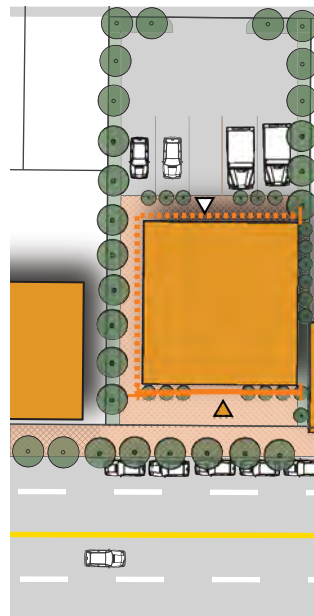

Small Lot
Option 2

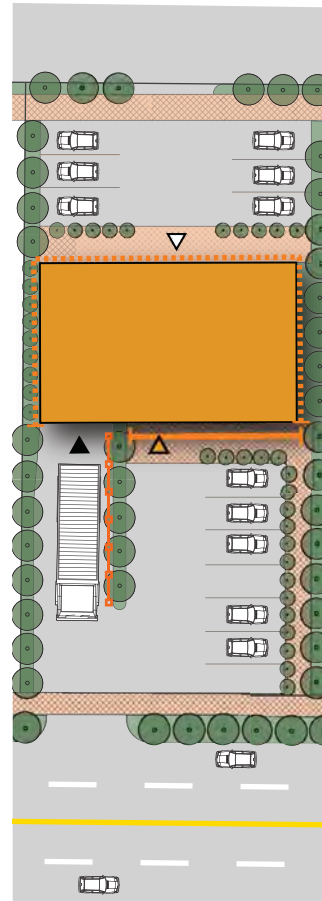

Medium Lot
Poor Design

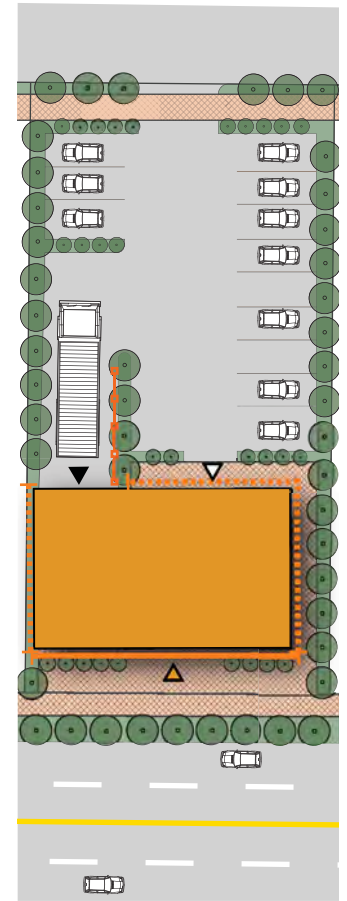

Medium Lot
Good Design

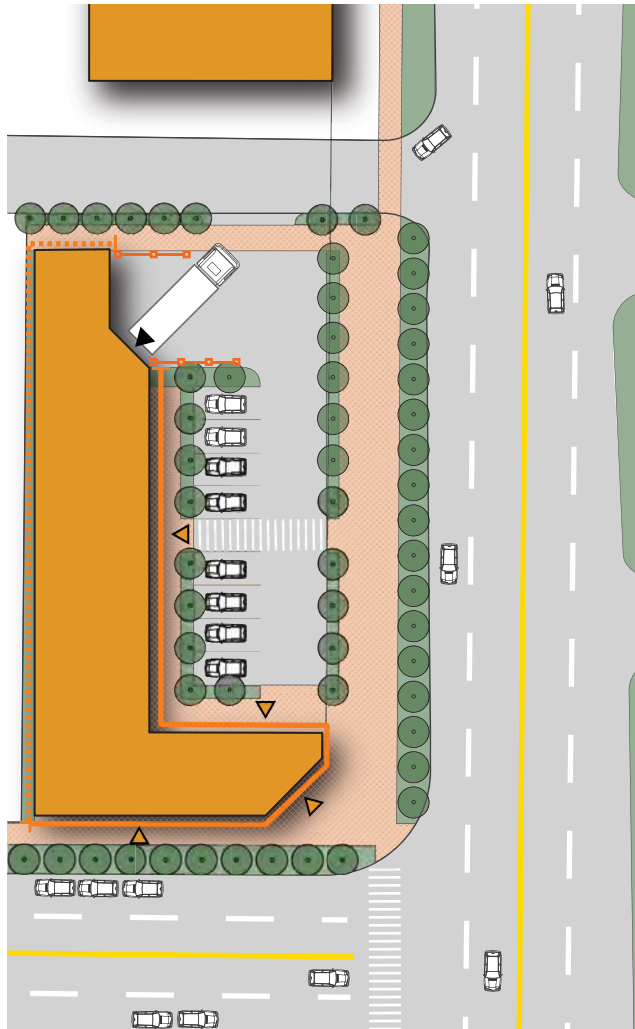

Corner Lot

Option 1

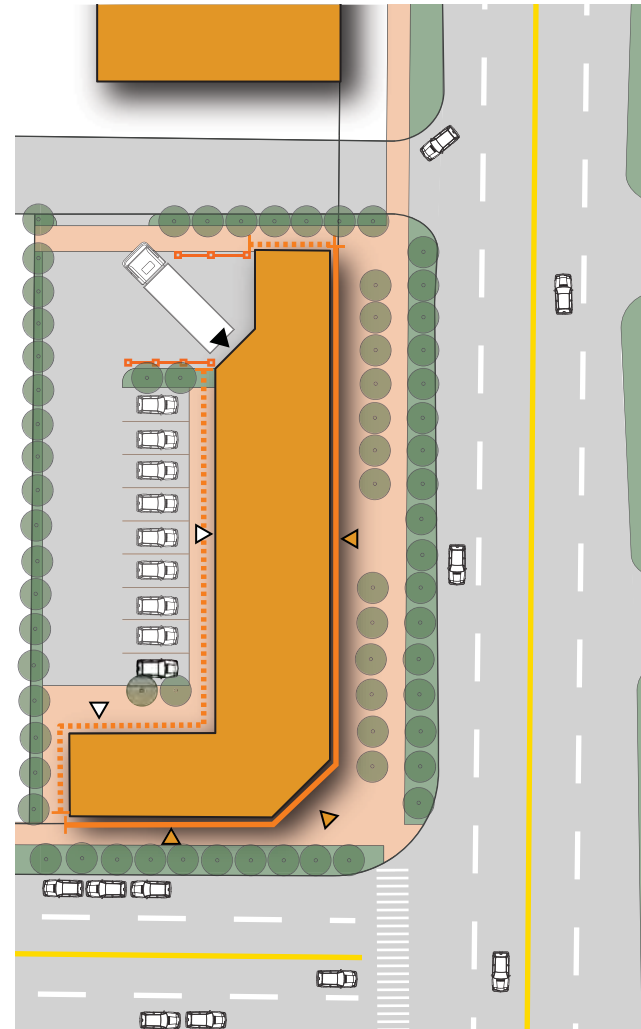

Corner Lot

Option 2



Combined Lot

Option 1

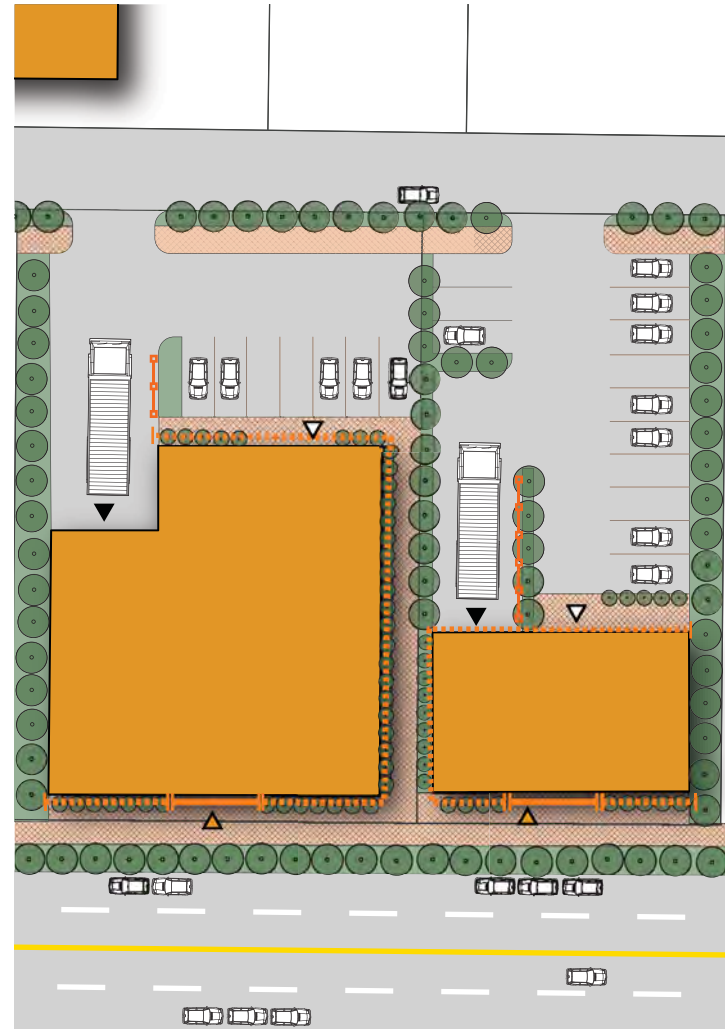

Combined Lot

Option 2

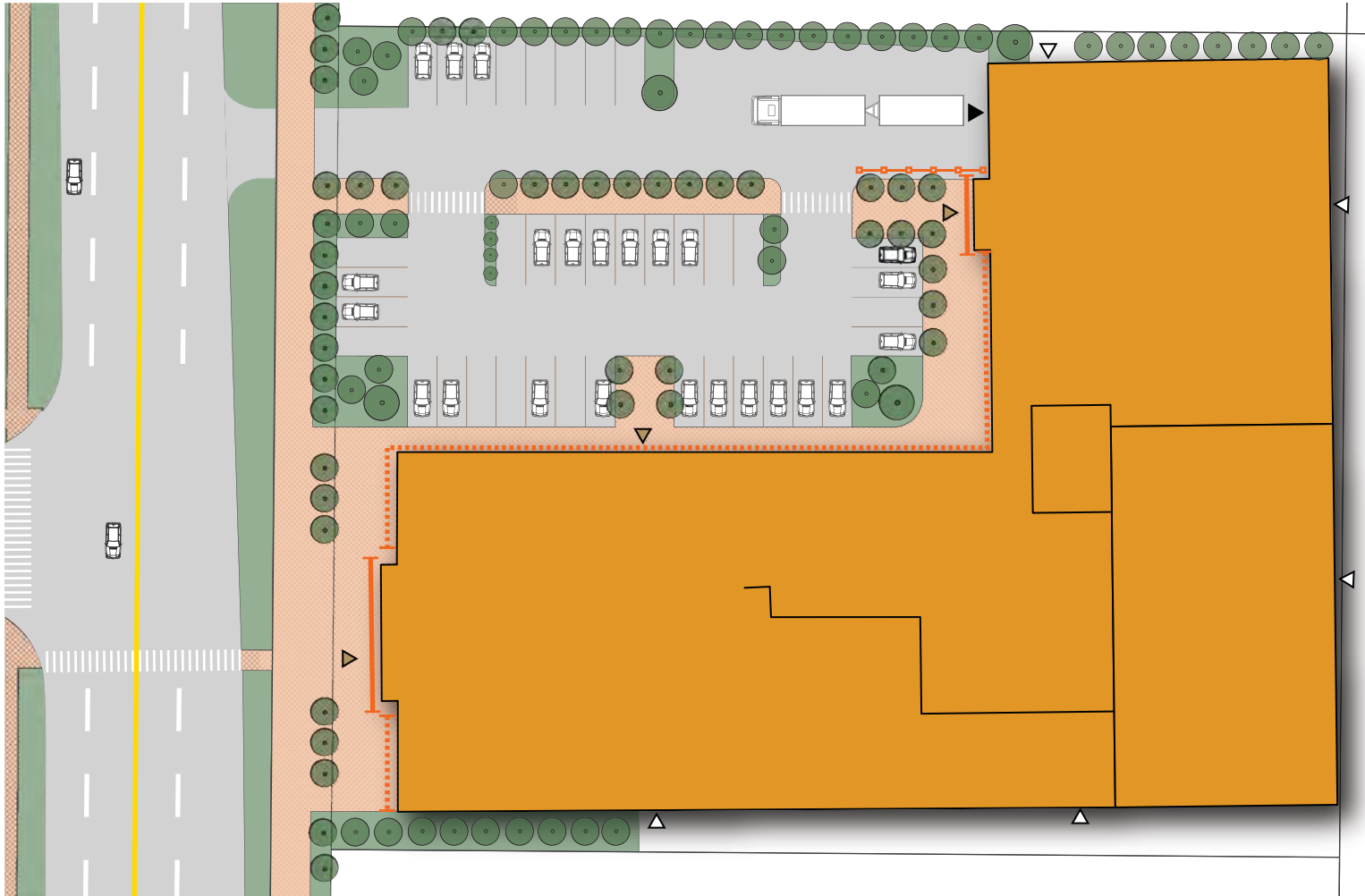

Big Lot
Option 1

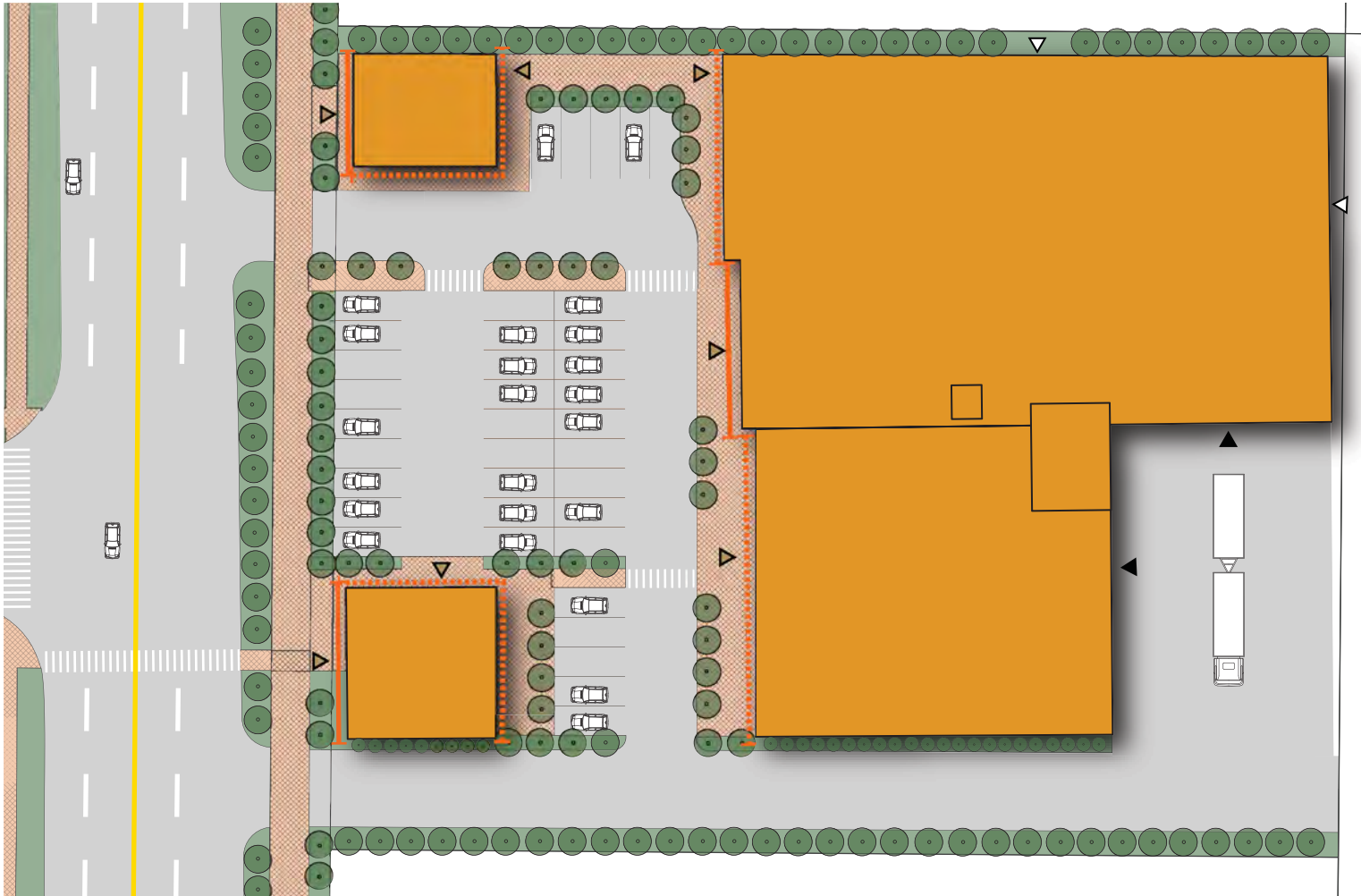

Big Lot
Option 2

Architecture Guideline

Storefront Guideline

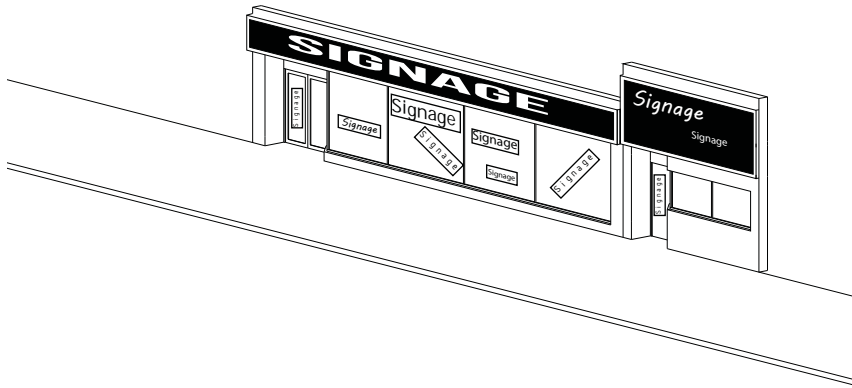

Poor Design

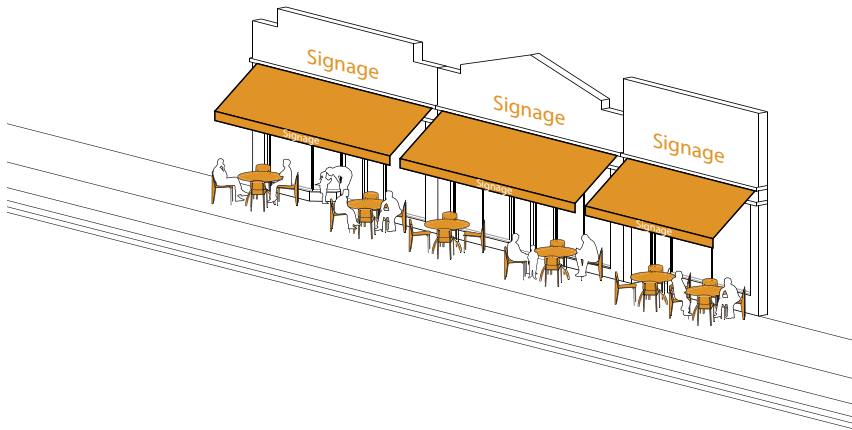

Good Design

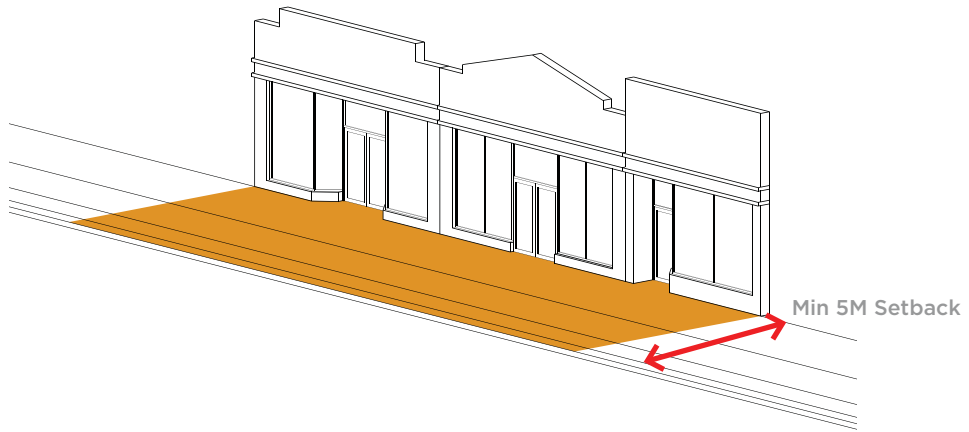

BUILDING SETBACK

Building must be set back to provide 5 m distance between the building façade to the curb





MATERIALS

Utilize bright and durable materials that can withstand the harsh winter.



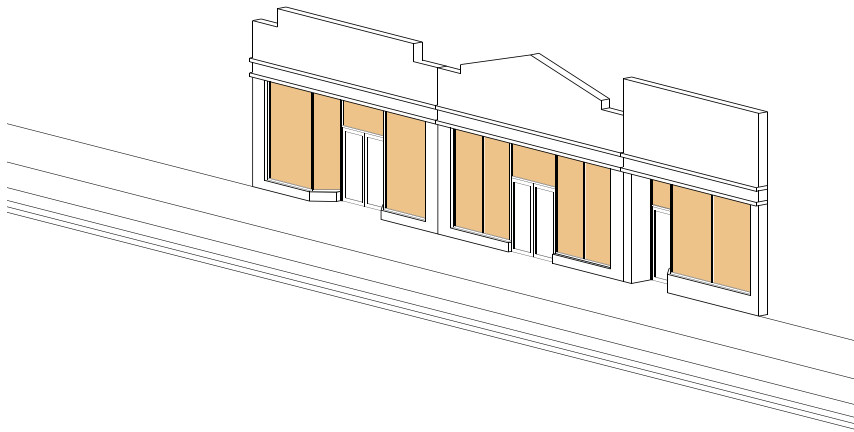

WINDOWS

Maximize the height of display windows

Minimize the size of the kick plate

Minimize the number of window frames – if multiple panes are required, seam the panes together

Do not glaze or frost large portions of windows

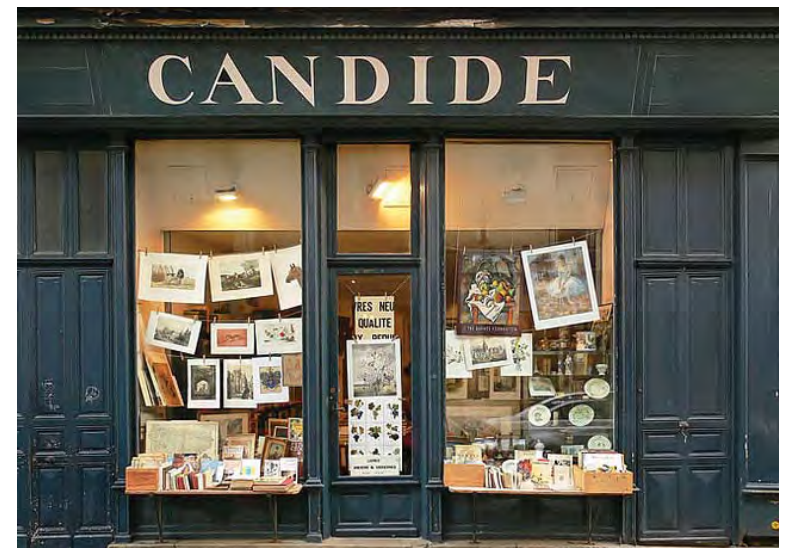

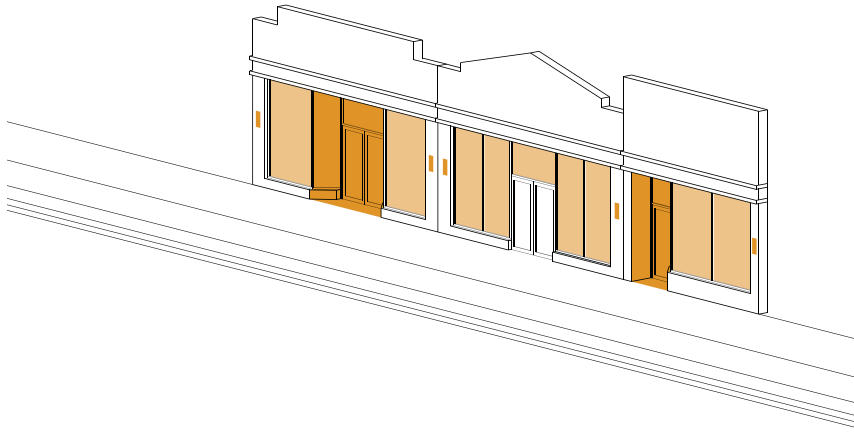

LIGHTING

Window display should be appropriately lit at night

Illuminate architectural features such as columns or pilaster

Appropriately illuminate any doorway recessions

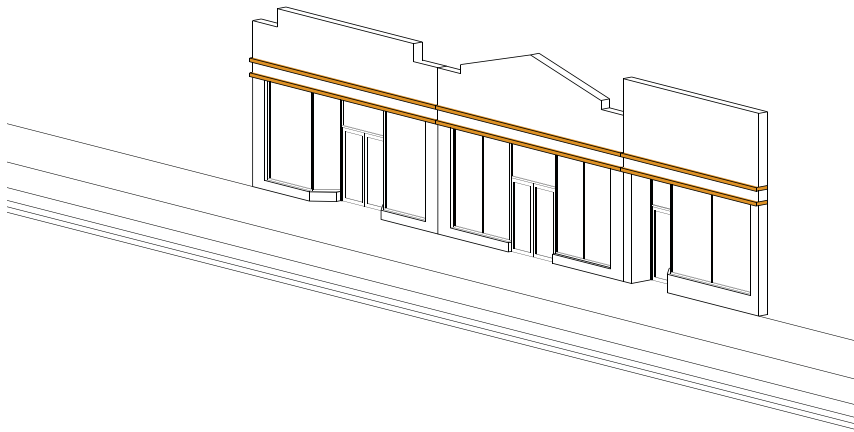

DETAIL

Minimize ornamental details (trim, molding, etc) by using straight lines (simple pilasters, sign bands, etc)

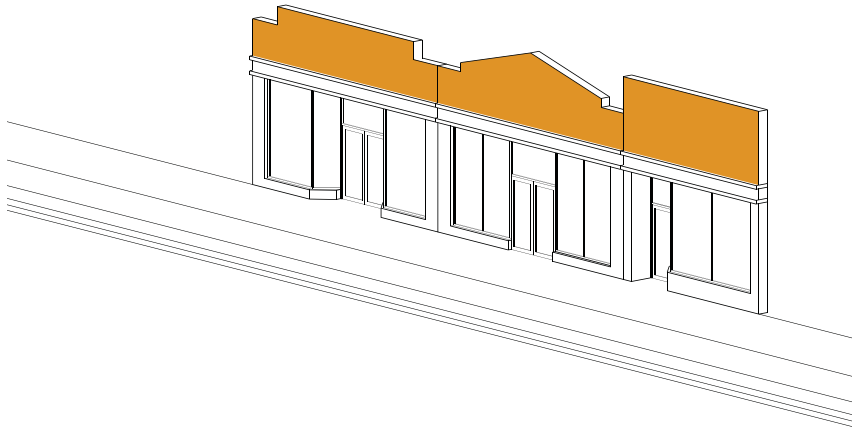

HEIGHT

Maximize the vertical presence of the store by raising sign boxes, sign bands and boxes to 3 feet. Doing so will maximize the size and street presence of display windows.

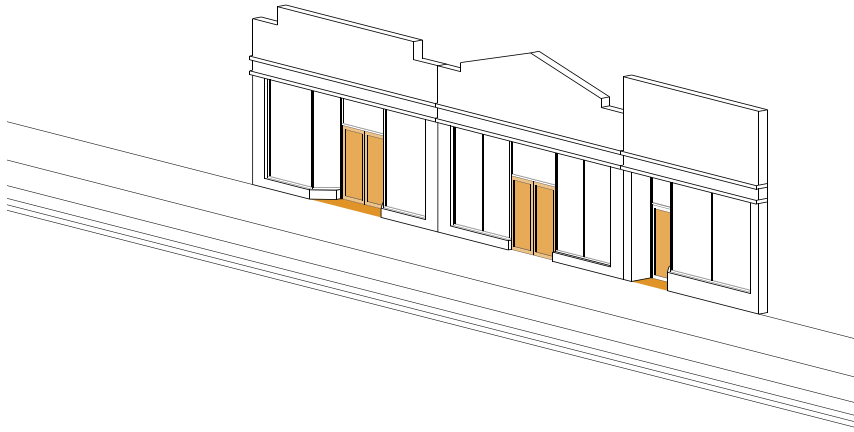

ENTRYWAYS

Design entranceway to ensure ease of customer access;

Minimize doorway recessions to accommodate outward swinging doors only;

Maximize the doorway width - where size permits introduce double doors;

Use glass doors to encourage visibility into the store



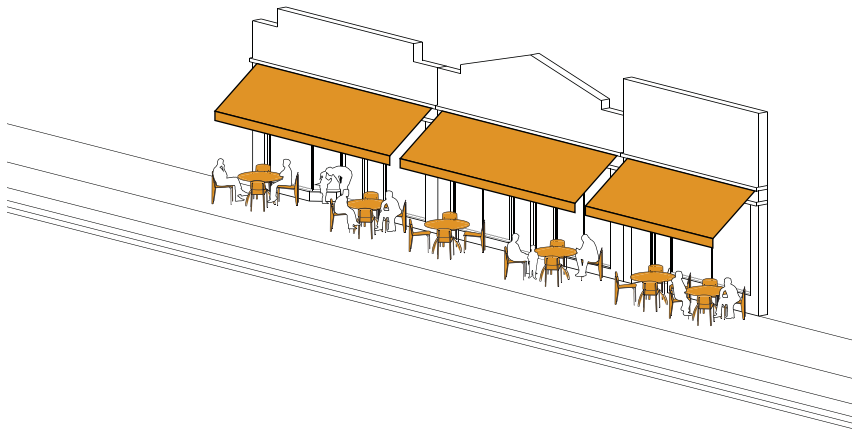

SOCIAL GATHERING SPACES

Small public gathering places on side-street flankages that encourage people to spend time and linger in the area.

These spaces could be used for cafe areas attached to restaurants or informal seating areas with tree canopy for shading.

The gathering spaces will encourage informal socializing and performances.

As some of the sidewalks are narrow, future streetscape improvements can take advantage of the wider public boulevards on the side streets.





HEALTHY STREET

Add planters in front of stores

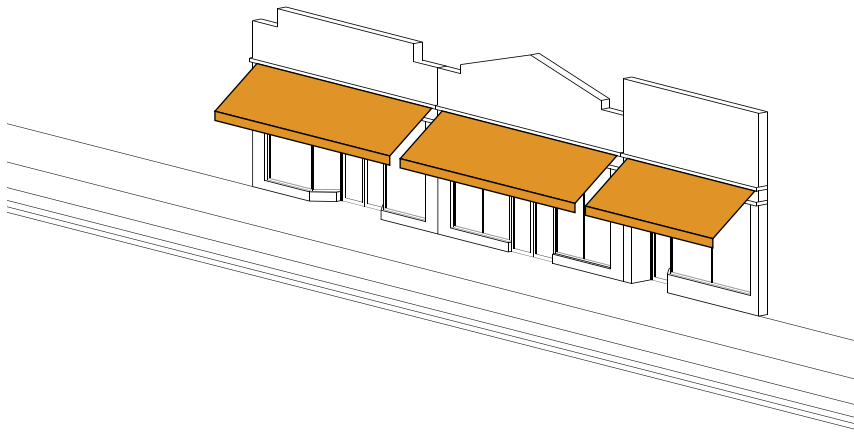

PROJECTIONS

To create an interesting streetscape, consider introducing architectural elements which project out from the façade (such as projecting signs, awnings, etc.). Note – certain projecting features may require an easement agreement)

Weather Protection



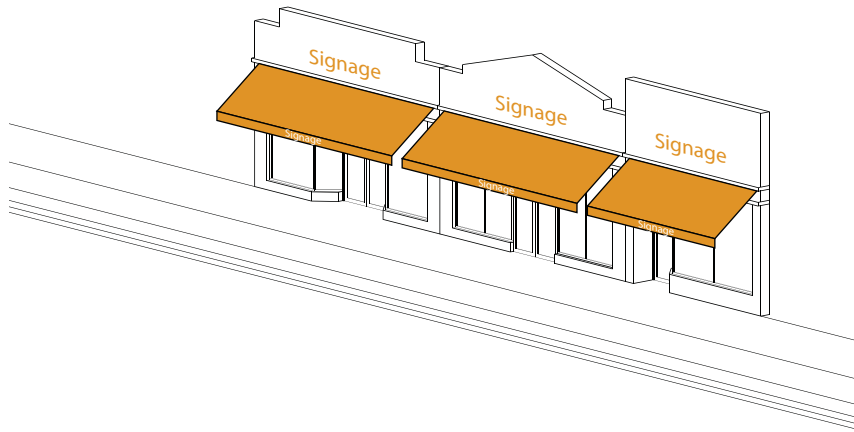

SIGNAGE



Storefront Guideline for Large Retail

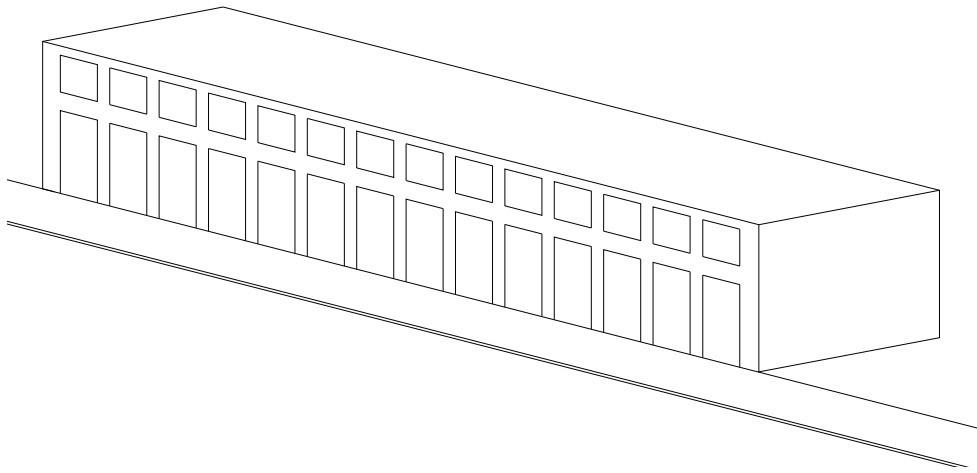

Poor Design

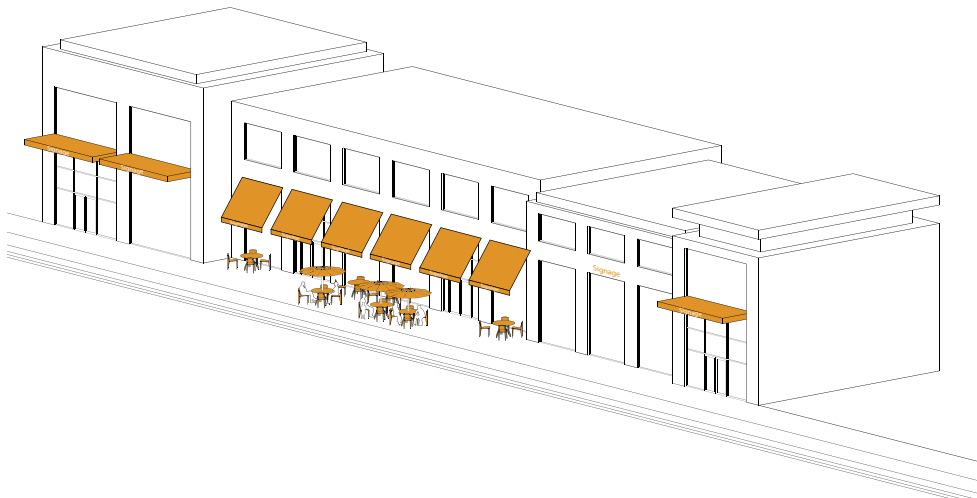

Good Design

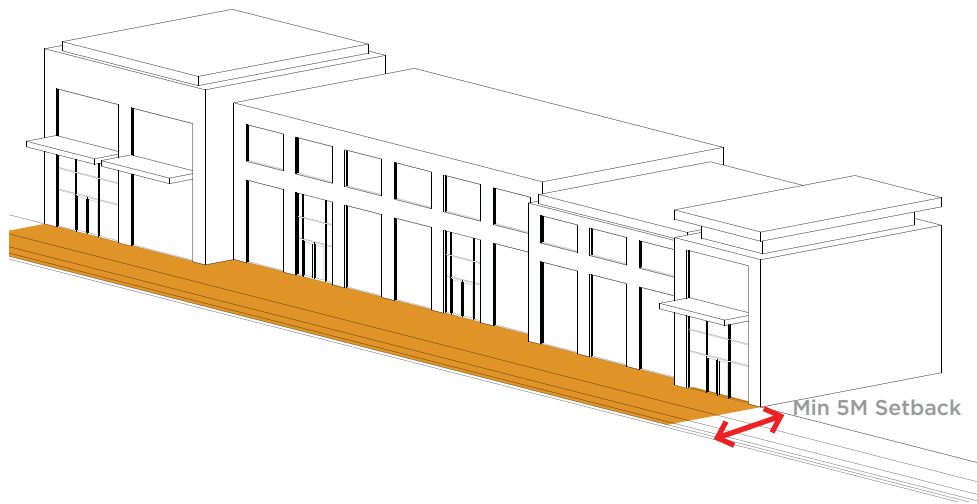

BUILDING SETBACK

Building must be set back to provide 5 m distance between the building façade to the curb



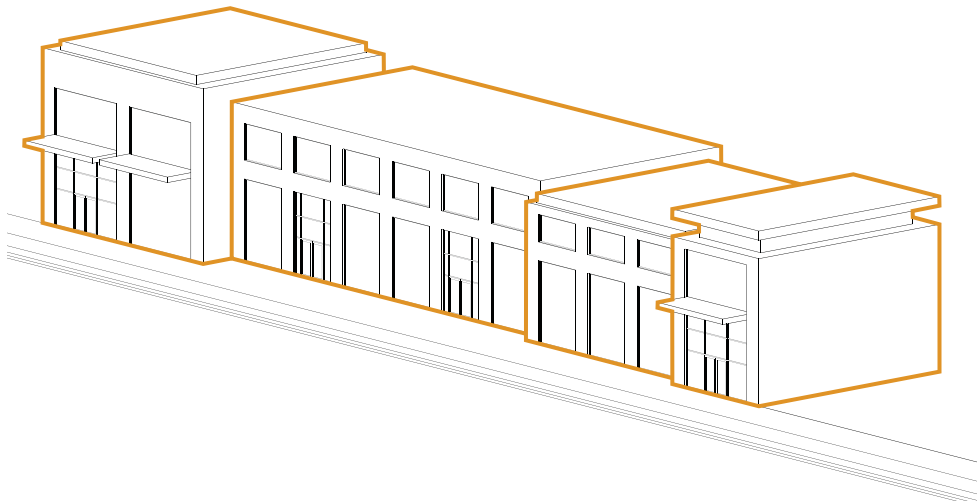

MASSING

Add scale and interest to the building facade by articulated massing

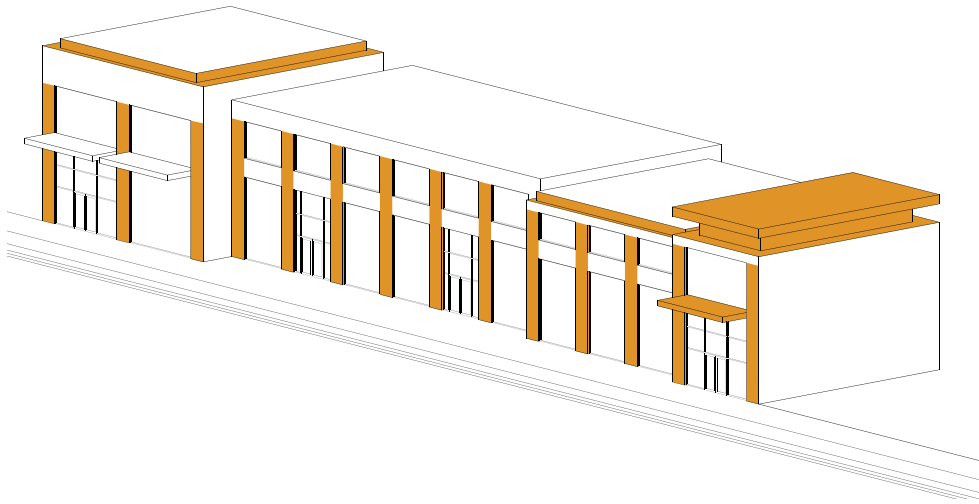

ARCHITECTURE ELEMENT

Discourage blank walls.

Incorporate architectural features



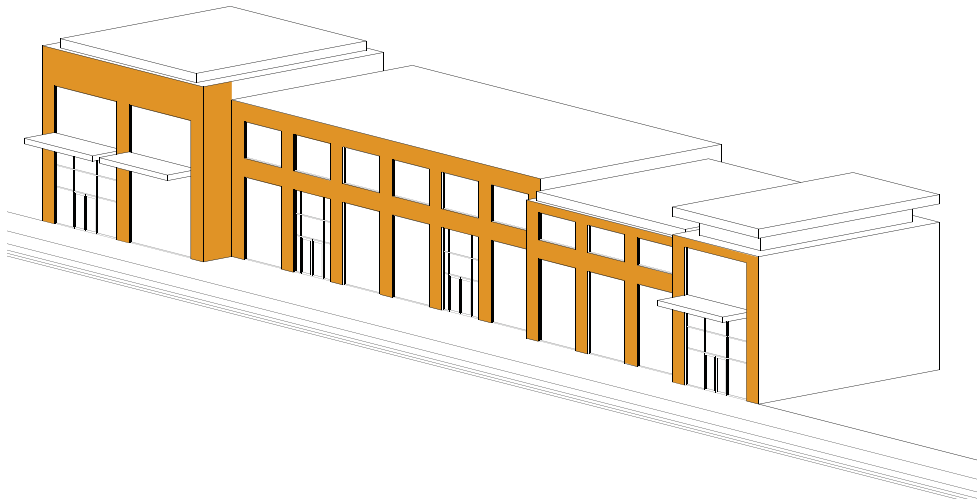

MATERIALS

Utilize bright and durable materials that can withstand the harsh winter.

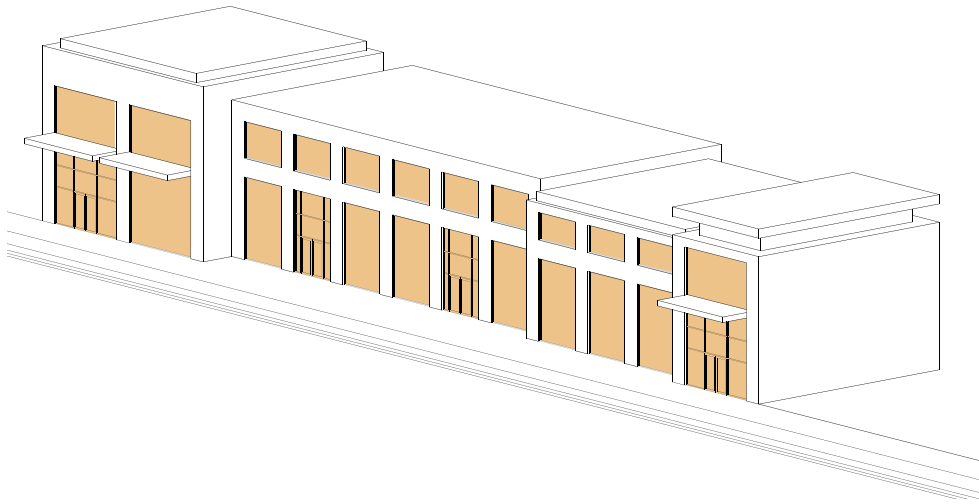

WINDOWS

Maximize the height of display windows

Minimize the number of window frames – if multiple panes are required, seam the panes together

Do not glaze or frost large portions of windows

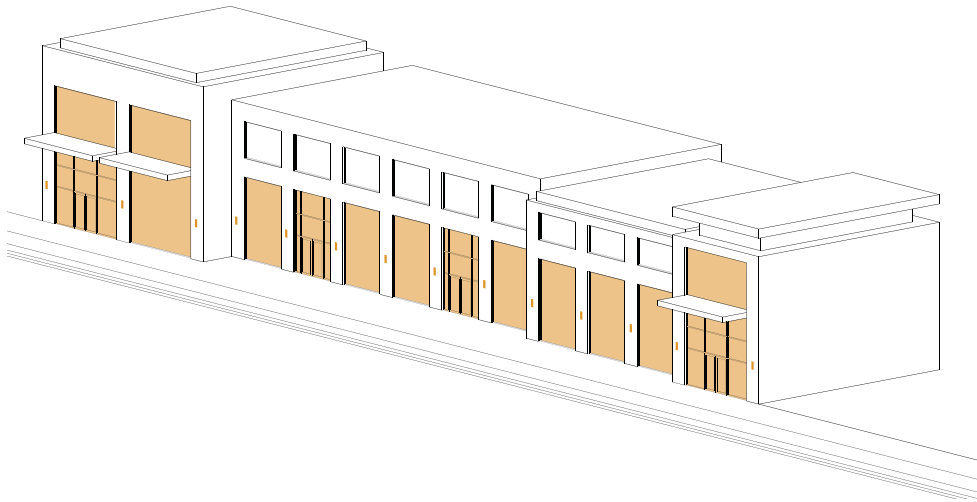

LIGHTING

Window display should be appropriately lit at night

Illuminate architectural features such as columns or pilaster

Appropriately illuminate any doorway recessions



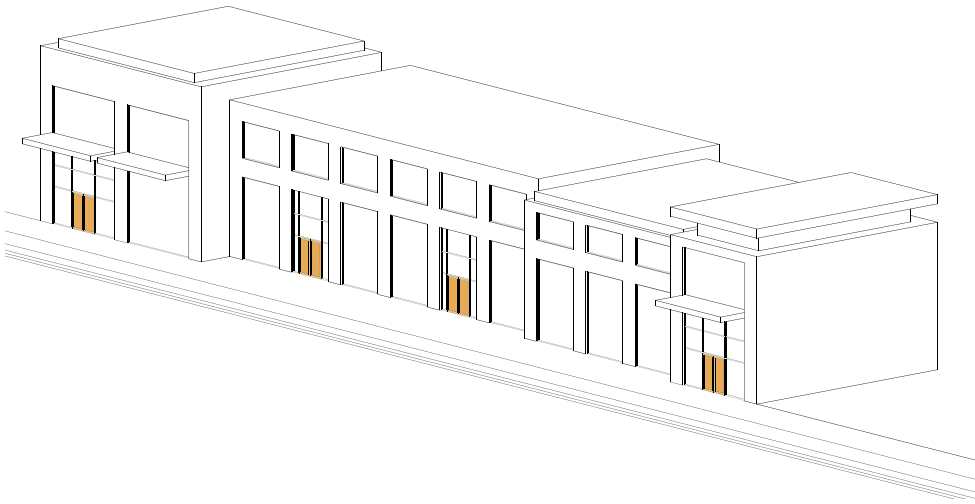

ENTRYWAYS

Design entranceways to ensure ease of customer access;

Minimize doorway recessions to accommodate outward swinging doors only;

Maximize the doorway width - where size permits introduce double doors;

Use glass doors to encourage visibility into the store.



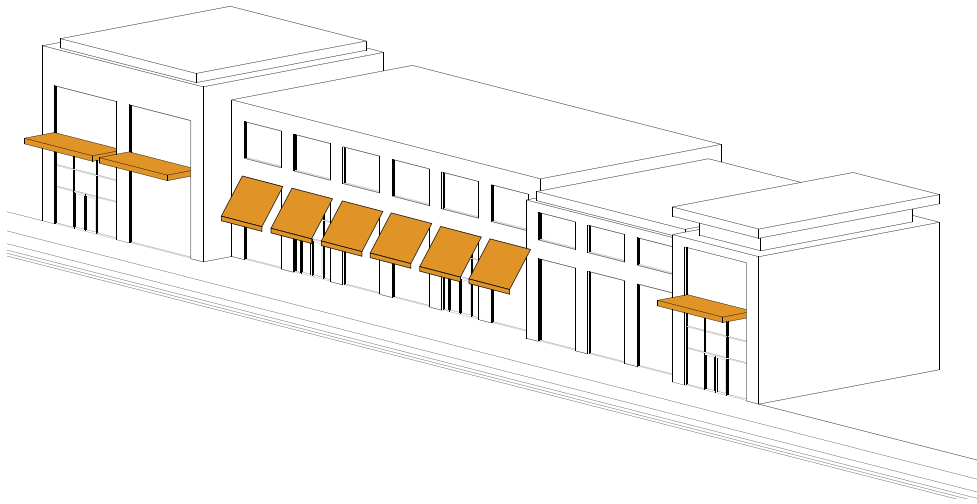

PROJECTIONS

To create an interesting streetscape, consider introducing architectural elements which project out from the façade (such as projecting signs, awnings, etc.). Note - certain projecting features may require an easement agreement)

Weather Protection

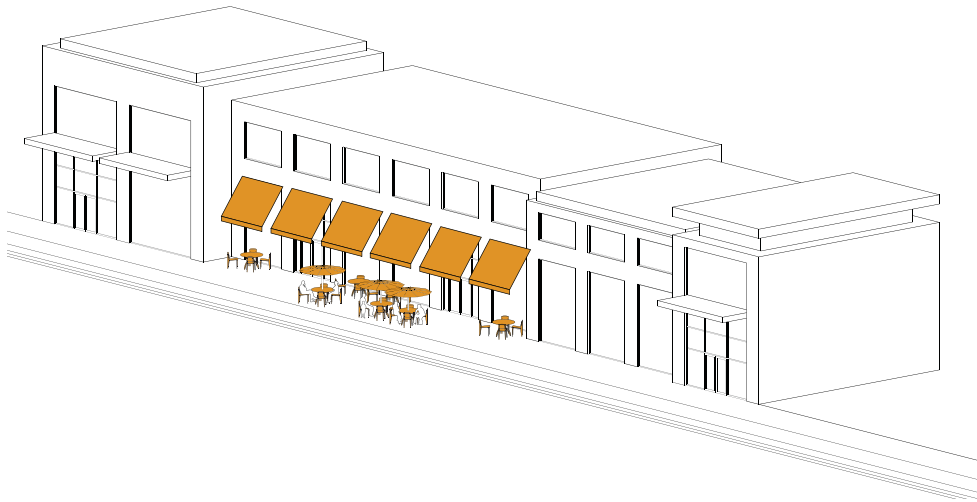

SOCIAL GATHERING SPACES

Small public gathering places on side-street flankages that encourage people to spend time and linger in the area.

These spaces could be used for cafe areas attached to restaurants or informal seating areas with tree canopy for shading.

The gathering spaces will encourage informal socializing and performances.

As some of the sidewalks are narrow, future streetscape improvements can take advantage of the wider public boulevards on the side streets.

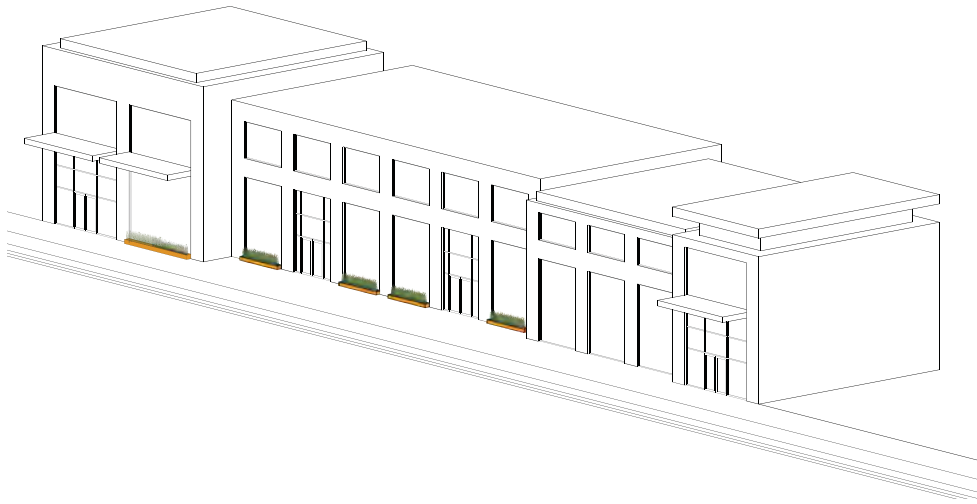

HEALTHY STREET

Add planters in front of stores



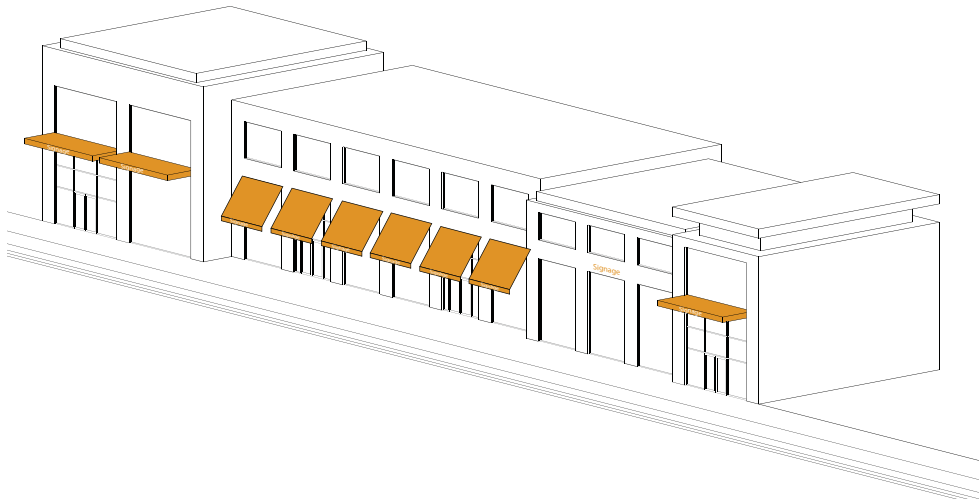

SIGNAGE